

## SMART-A

SMART-A 70% / 200 Kg				
	m	e	f	h
9L	200	209	95	1560
8L	200	209	95	1560
7L	200	209	125	1560
6L	200	209	155	1560
5L	200	209	215	1560
4L	200	209	275	1560
3L	200	209	395	1560
2L	200	209	605	1560
1L	200	209	1308	1560

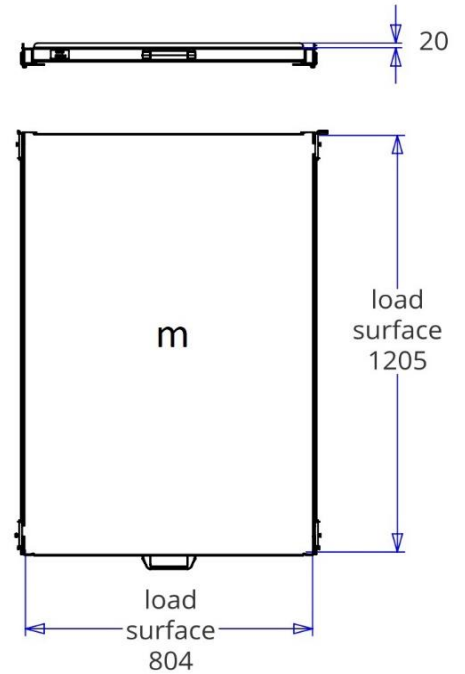

TYPE DESCRIPTION, TYPE AANDUIDING, TYPBEZEICHNUNG, TYPE INDICATION

SMART - 8L20A - 80 X 120

SMART - 8L20A - 80 X 120 - Lock (with shelf lock)

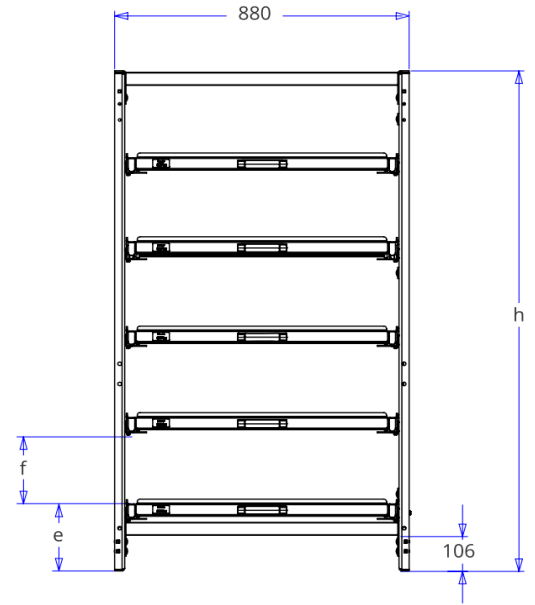
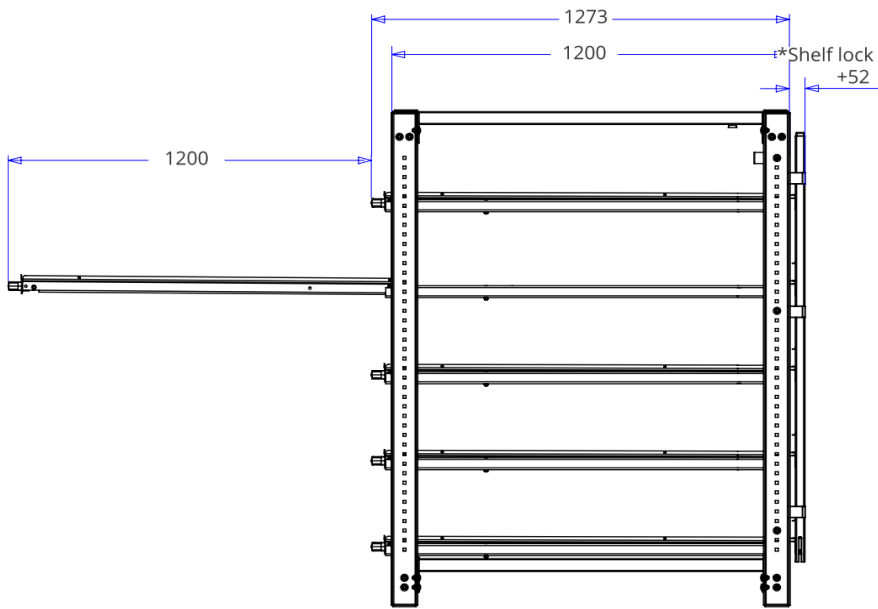

## SMART-B

SMART-B 100% / 150 Kg				
	m	e	f	h
9L	150	234	66	1560
8L	150	234	66	1560
7L	150	234	96	1560
6L	150	234	126	1560
5L	150	234	186	1560
4L	150	234	246	1560
3L	150	234	366	1560
2L	150	234	547	1560
1L	150	234	1256	1560

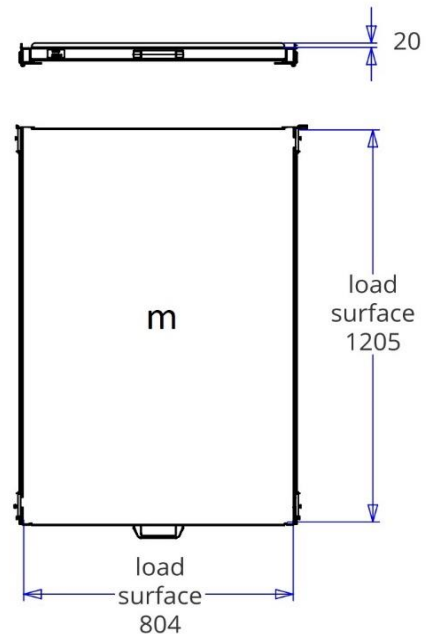

TYPE DESCRIPTION, TYPE AANDUIDING, TYPBEZEICHNUNG, TYPE INDICATION

SMART - 6L15B - 80 X 120

SMART - 6L15B - 80 X 120 - Lock (with shelf lock)

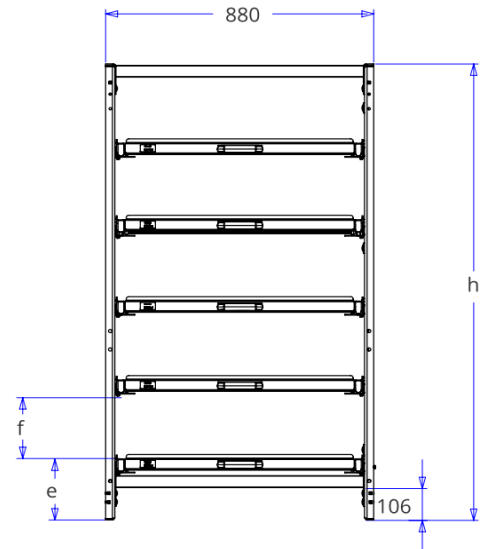
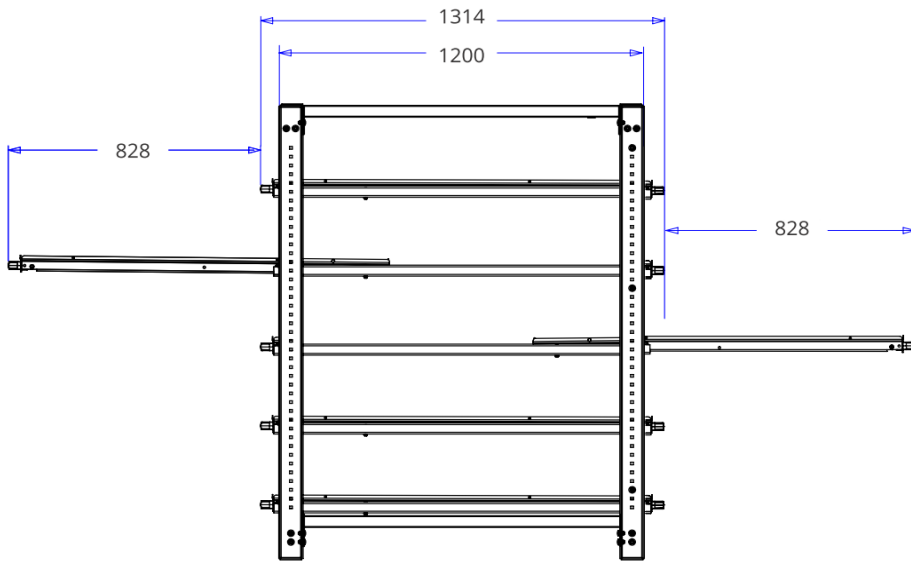

## SMART-D-A

SMART-D-A 70% / 200 Kg				
	m	e	f	h
9L	200	208	102	1560
8L	200	208	102	1560
7L	200	208	132	1560
6L	200	208	162	1560
5L	200	208	222	1560
4L	200	208	282	1560
3L	200	208	402	1560
2L	200	208	612	1560
1L	200	208	1315	1560

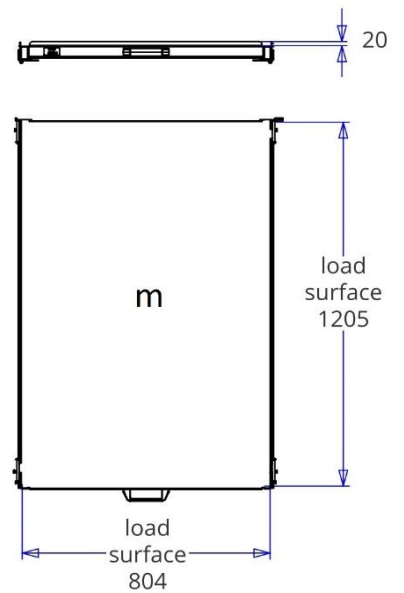

TYPE DESCRIPTION, TYPE AANDUIDING, TYPBEZEICHNUNG, TYPE INDICATION  
SMART-D - 5L20A - 80 X 120